



MAX LIGHT

PERFORMANCE LEVEL

UW-VALUE ML DESIGN/STEEL		0.97 W/m²K*
UF-VALUE		1.8 W/m²K
AIR TRANSMISSION	NBN EN 12207	Classe 4
WATERTIGHTNESS	NBN EN 12208	Classe E1650
RESISTANCE TO WIND	NBN EN 12210	Classe C5
SHOCK RESISTANCE	EN 13049	Classe 5
BURGLARPROOF	NEN 5096 & ENV 1627	RC2
OPERATING PROOF	EN 13115	Classe 1
ACOUSTICAL INSULATION		up to 47.2dB (-2 ; -6.3)
FIRE RESISTANT		EW30 - EW60 - EI30

* 1230mm x 1480mm / UG 0.6W/m²K & PSI 0.036W/MK / profile combination: ML810-ML820 / ML610-620

APPLICATIONS

- Fixed Windows
- Pivoting windows:
 - Single or double hinged with the option of tilting
 - Possible pivot direction: inside opening
- Inside and outside opening doors: single or double
- Foundation for conservatories
- Round or curved windows

100% MADE IN BELGIUM



Aliplast develops aluminium profiles tailored to current housing needs. Everything happens under one roof: from drawing to extrusion, powder coating, insulation and transport to the Aliplast distributors. The distributors produce and install the finished windows in your building project.

25-YEAR COLOUR GUARANTEE



Aliplast gives a 25-year guarantee on 50 current colours. The Qualicoat Seaside quality label ensures that your paint colour is extra protected against aggressive environments (exhaust fumes, salty sea air, etc.). You enjoy a 15-year guarantee on all other colours. Peace of mind for the future.

DURABLE PRODUCT



Aluminium is a durable product because it has a long lifespan. Moreover, the material is fully recyclable and can therefore be completely reused without compromising on quality. Aliplast was awarded the Cradle to Cradle certificate on this system: it is suitable for circular construction, it has a positive impact on people and the environment, it contains no harmful substances and is manufactured using green energy.



MAX LIGHT

Ultra-slim windows in 4 styles
Modern - Steel - Design - Invisible

100%
MADE IN
BELGIUM

25
YEARS
COLOR
LOCKED

aliplast[®]
ALUMINIUM SYSTEMS

ALIPLAST PLC

WAASLANDLAAN 15 | B - 9160 LOKEREN | INFO@ALIPLAST.COM | WWW.ALIPLAST.COM

ML-EN-202306

MAX LIGHT

STYLE VARIANTS



©Lukas De Groot / Kanto



'MODERN'

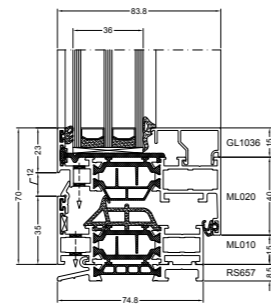

'DESIGN'

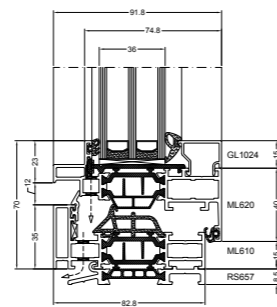

'STEEL'

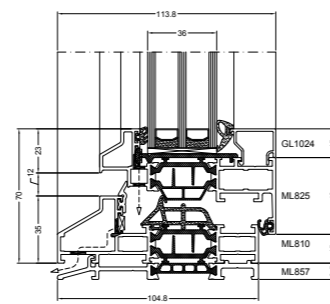

'INVISIBLE'

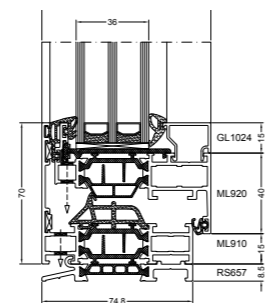

The **MAX LIGHT** system is designed for architectural projects that prioritise the combination of minimalist aesthetics, high-quality thermal insulation and comfort. The Max Light has 4 style variants: Modern, Steel, Design and Invisible (hidden vent) combined with double or triple glazing. Because of this flexibility, the Max Light is used in both modern new buildings and renovation projects.

	ML Modern	ML Steel	ML Design	ML Invisible
Minimum visible width inward opening window	Frame: 35 mm Pane: 35 mm	Frame: 35 mm Pane: 35 mm	Frame: 35 mm Pane: 35 mm	Frame (Hidden vent): 70 mm
Minimum visible width inward opening door	Frame: 35 mm Pane: 68 mm	Frame: 35 mm Pane: 68 mm	Frame: 35 mm Pane: 68 mm	NVT
Minimum visible width outward opening door	Frame: 15 mm Pane: 88 mm	Frame: 15 mm Pane: 88 mm	Frame: 15 mm Pane: 88 mm	NVT
Minimum visible width T-profile	50 mm	50 mm	50 mm	NVT
Installation depth frame	75 mm	105 mm	83 mm	75 mm
Installation depth pane	84 mm	97 mm	92 mm	84 mm
Rebate height	15 mm	15 mm	15 mm	15 mm
Glass thickness	up to 68 mm	up to 59 mm	up to 59 mm	up to 59 mm